

Project1 / PLC_1 [CPU 1212C DC/DC/DC] / Program blocks

Main [OB1]

Main Properties

General

Name	Main	Number	1	Type	OB
Language	LAD	Numbering	automatic		

Information

Title	"Main Program Sweep (Cycle)"	Author		Comment	
Family		Version	0.1	User-defined ID	

Main

Name	Data type	Default value
▼ Input		
Initial_Call	Bool	
Remanence	Bool	
Temp		
Constant		

Network 1:

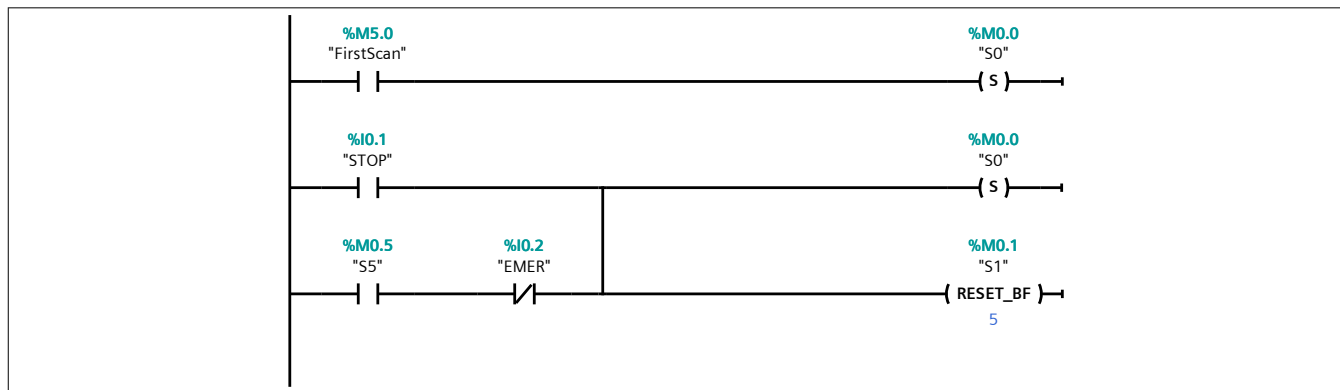

Network 2:

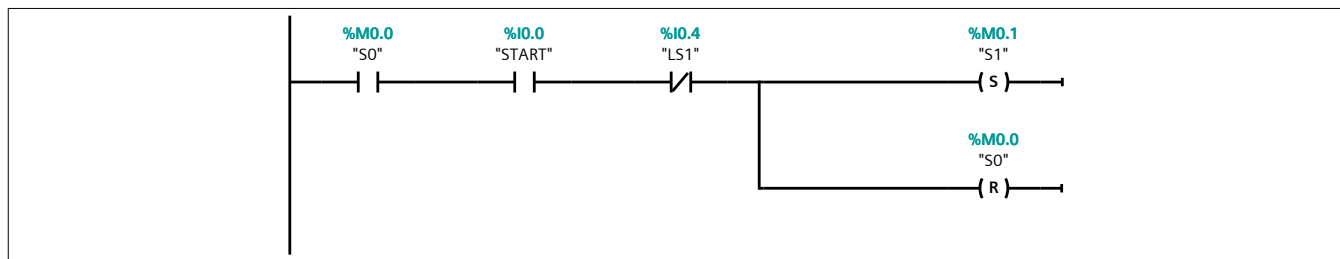

Network 3:

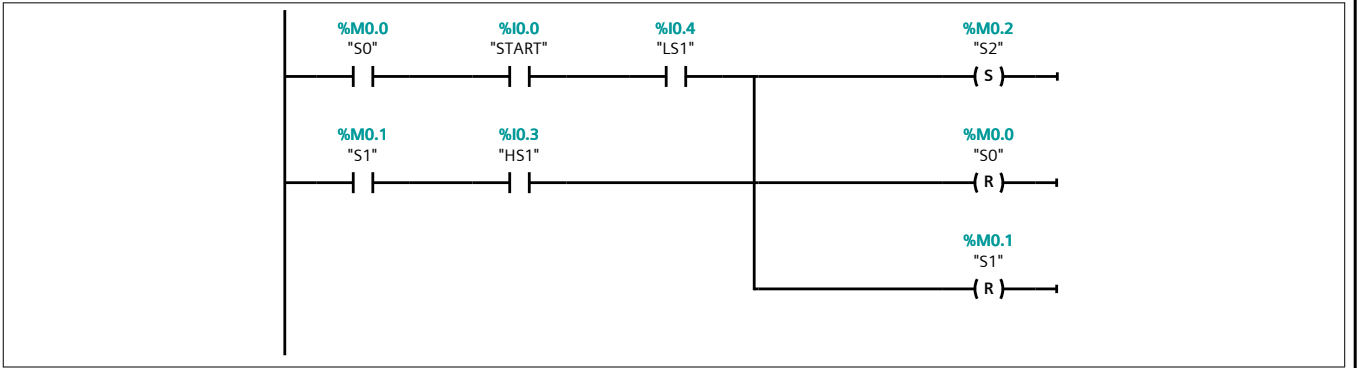

Network 4:

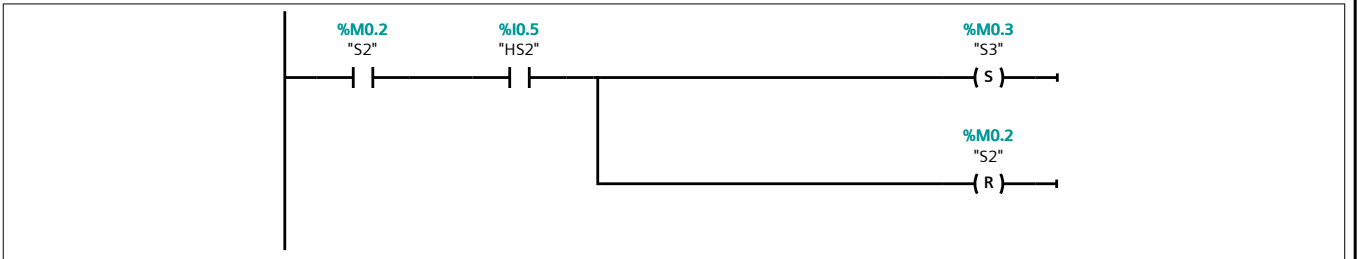

Network 5:

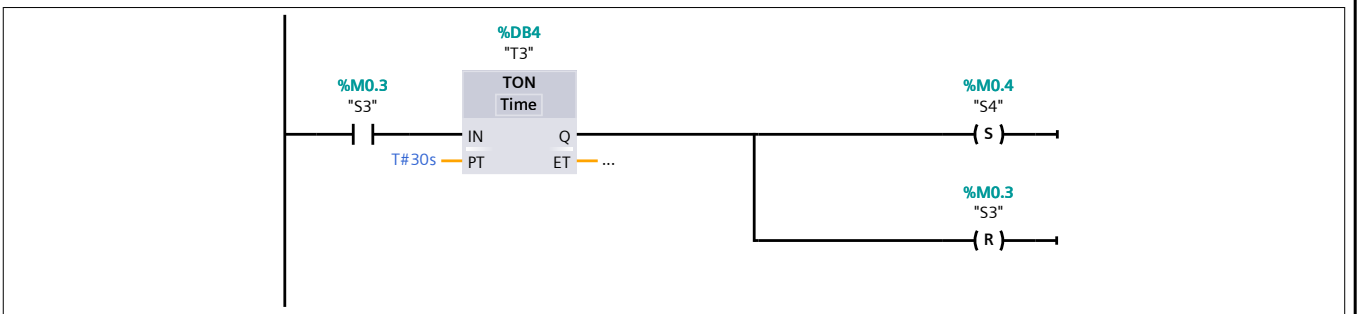

Network 6:

Network 6:

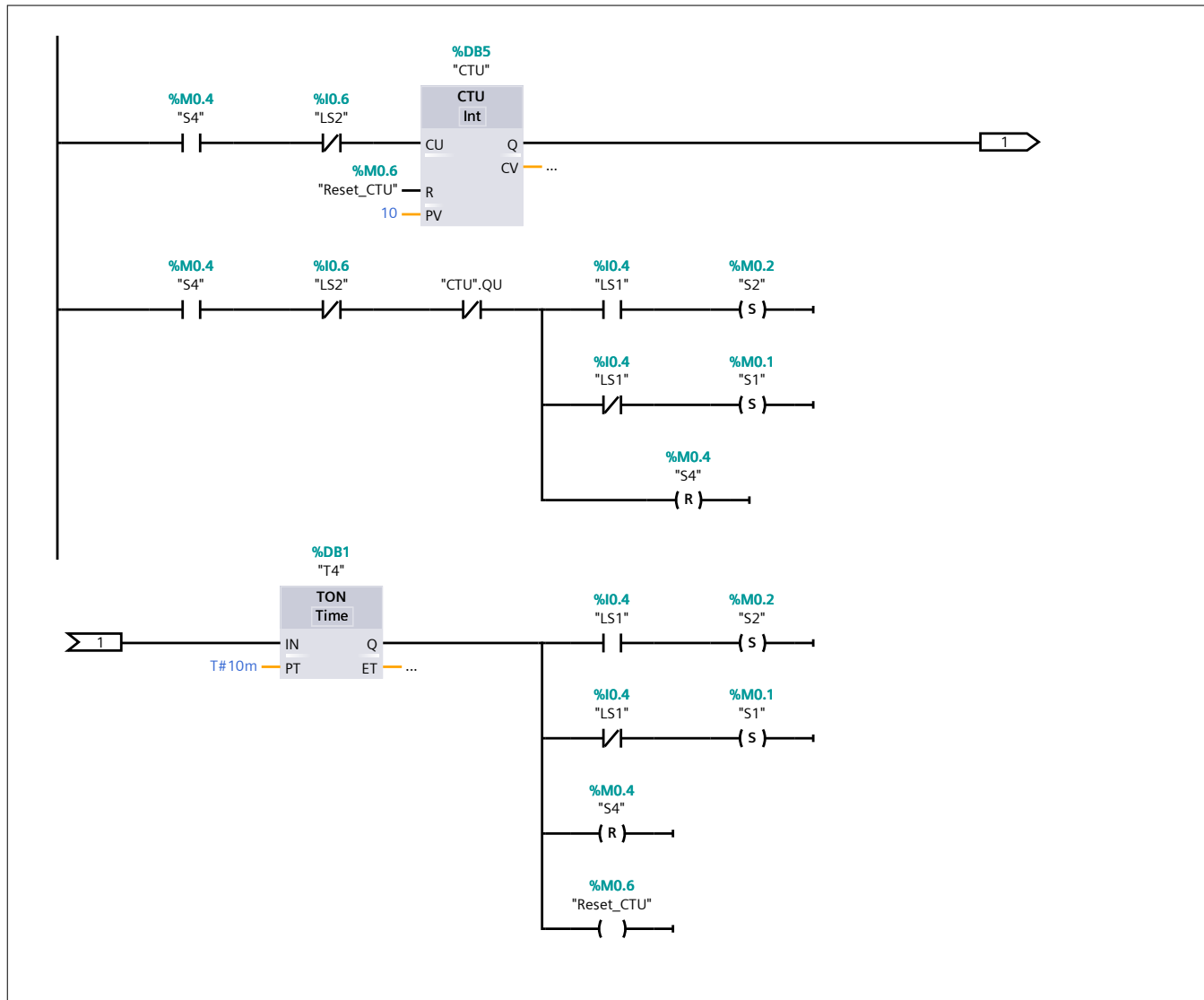

Network 7:

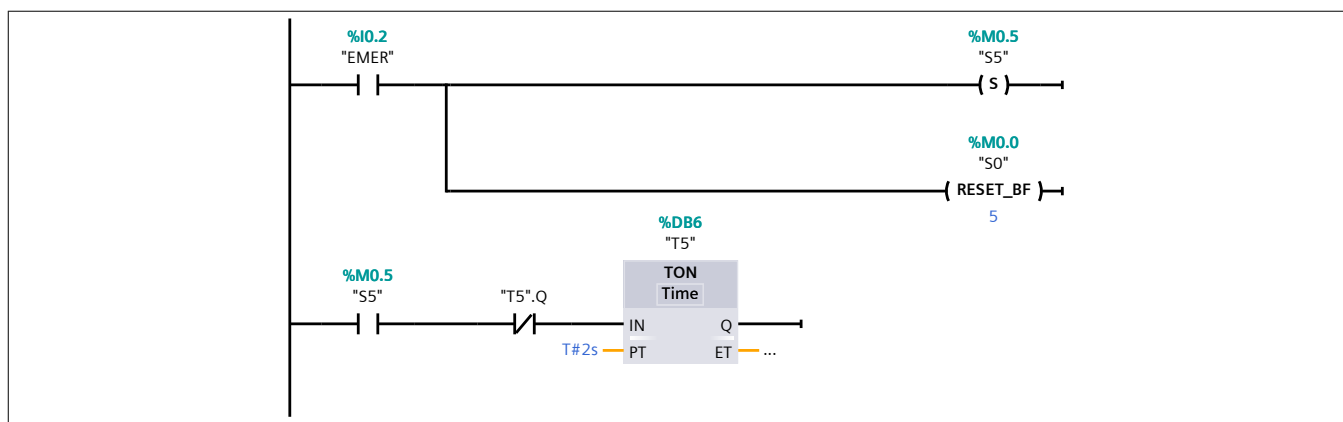

Network 8:



